



Hardinge FlexC™ Collet System
Style D — 65mm
Installation Instructions
and Parts Lists

General Safety Information

Before installing the Hardinge® FlexC™ Collet System on your machine tool, thoroughly read this manual and understand the information. If you are uncertain about any of the information, see your immediate supervisor. Also make certain that you understand the information in your machine tool operator's, programmer's and maintenance manuals.

NOTICE

Damage resulting from misuse, negligence or accidents
is not covered by the Hardinge FlexC warranty.

Information in this document is subject to change without notice.

In no event will Hardinge Inc. be responsible for indirect or consequential damage resulting from the use or application of the product, or any of the information in this document.

This product is only to be used by trained machinists skilled
in the use and operation of collet systems and collet chucks on metal cutting machines.

Safety Requirements to the Turning Machine:

Check to see that the workpiece is properly gripped and seated in the collet head before beginning the machining cycle.

Do not unclamp the workpiece until the machining cycle has come to a complete stop.

Observe all safety precautions indicated in the machine manual when operating the machine including the use of guards and keeping the door closed during machining.

Do not exceed the maximum operating force and rpm for the Hardinge FlexC Collet Systems indicated below:

Maximum operating force: 10,100 lb (45KN)

Maximum RPM: 6,000

Product Description and Use:

The Hardinge FlexC Style D Collet System consists of a spindle mount assembly. Vulcanized collet heads and wrenches are purchased separately. The Style D Collet System is designed with a thru-hole for bar work applications. Since there is no work stop in this model, this style is NOT recommended for chucking parts. The clamping heads consist of hardened steel segments that are joined together by a vulcanization process. Their outstanding characteristics are parallel workpiece clamping, superb accuracy, wide gripping range and quick-change capability.

The Hardinge FlexC Style D Collet System is a pull-back design. The collet draws in against the closing angle providing very stable gripping of the workpiece. The overall rigidity of the entire gripping unit has a very positive effect on tool wear.

CAUTION: Make sure that the workpiece is adequately gripped so that the workpiece will not come loose during the machining process. When clamping very short workpieces, the minimum clamping lengths must be observed. They depend on the selected clamping head size and shape – call Hardinge for guidance. Do not clamp tapered work pieces. In general the collet system should never be rotated without a clamped workpiece. Never rotate the collet system over 2,000 RPM without a clamped workpiece. When actuating the changing wrench, never reach inside the moving parts for risk of severely damaging your hand.

Drawbar Linkup

The Hardinge FlexC Collet System requires a drawbar linkup to mate the specific machine drawbar (varies by machine brand and model) to the FlexC clamping sleeve. This linkup can be ordered from Hardinge or can be made by the customer.

Cleaning and Maintenance

The spindle, collet head and the spindle mount mating surfaces must be cleaned and free of chips and sludge whenever mounting to the spindle or changing out a collet head. Visually inspect collets for tearing or separation of rubber on a regular basis during long job runs and during setup. If you are using a high pressure coolant in your machining processes, you need to inspect the collets more frequently. Do NOT clean an open spindle with an air hose as chips and sludge may be forced into the spindle drawbar area. Clean and lubricate all moving parts with Chevron Ultra-Duty EP NLGI 2, Dow Corning BR-2-Plus, or Kluber ALTEMP Q NB 50 grease. Store all unused products properly to prevent corrosion and keep free of dust and environmental particles.

Check to see that all mounting screws are in good condition and replace when worn. All components must be replaced with original Hardinge replacement parts.

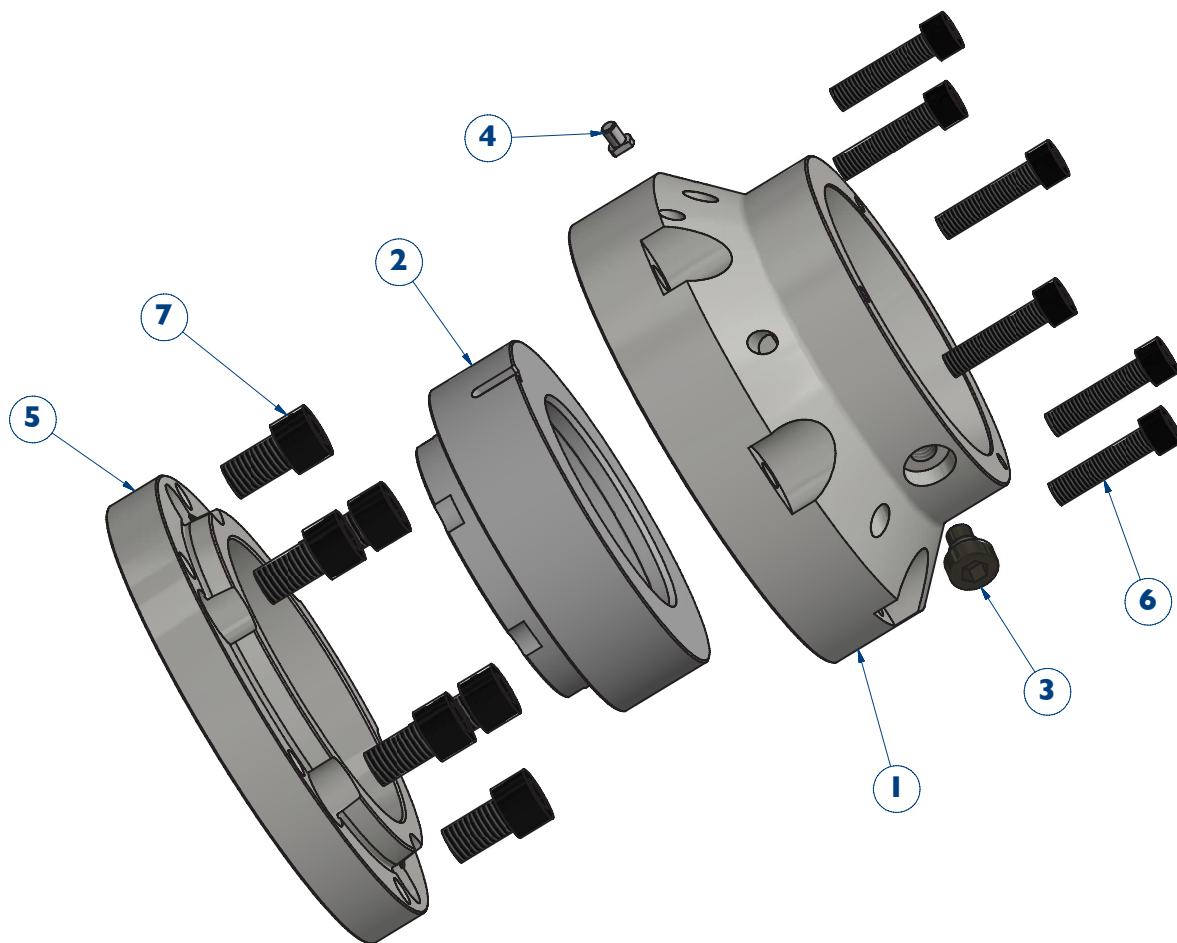

V65 5D00550 Parts List

ITEM	PART NUMBER	QTY	DESCRIPTION
1	V65 6D00552	1	FLEXC 65 D COLLET SEAT
2	V65 6D00553	1	FLEXC 65 D CLAMP SLEEVE (NOT INCLUDED IN ASSEMBLY)
3	V65 01207	1	KEYSCREW
4	V65-01603	1	LOCATING STUD
5	V65 5DL05731	1	SPINDLE ADAPTER A2-5
6	MS 0103821	6	M8-1.25 x 35MM S.H.C.S. (26ft-lb/36Nm)
7	MS 0104018	6	SCREW SOC HD CAP M10 x 1.5 x 20MM (40ft-lb/54Nm)

V65 6D00650 Parts List

ITEM	PART NUMBER	QTY	DESCRIPTION
1	V65 6D00552	1	FLEXC 65 D COLLET SEAT
2	V65 6D00553	1	FLEXC 65 D CLAMP SLEEVE (NOT INCLUDED IN ASSEMBLY)
3	V65 01207	1	KEYSCREW
4	V65-01603	1	LOCATING STUD
5	V65 6DL05831	1	SPINDLE ADAPTER A2-6
6	MS 0103821	6	M8-1.25 x 35MM S.H.C.S. (26ft-lb/36Nm)
7	MS 0104218	6	SCREW, SHCS M12X1.75X20MM (60ft-lb/81Nm)

Part No. BC -0009500-0154

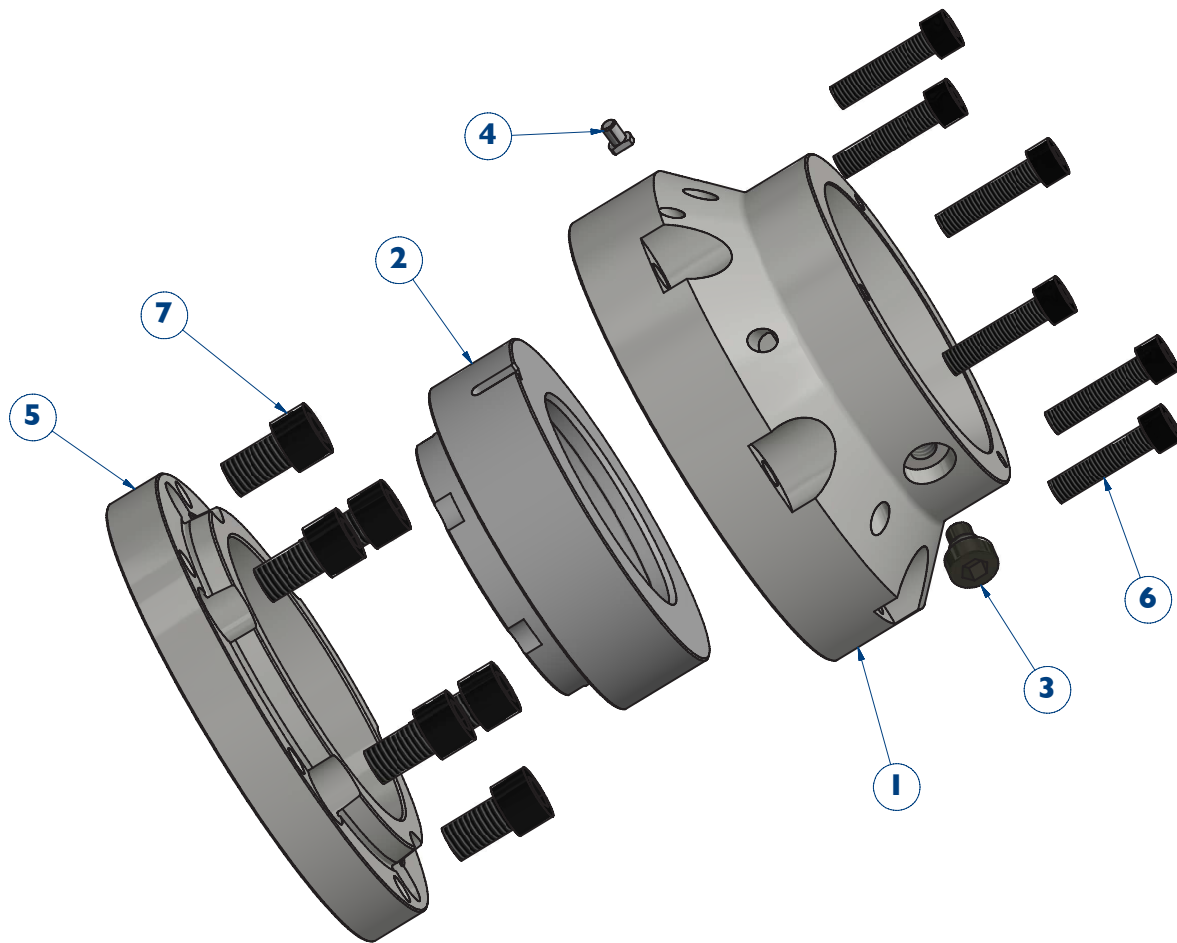

V65 8D00750 Parts List

ITEM	PART NUMBER	QTY	DESCRIPTION
1	V65 6D00552	1	FLEXC 65 D COLLET SEAT
2	V65 6D00553	1	FLEXC 65 D CLAMP SLEEVE (NOT INCLUDED IN ASSEMBLY)
3	V65 01207	1	KEYSCREW
4	V65-01603	1	LOCATING STUD
5	V65 8DL06031	1	SPINDLE ADAPTER A2-8
6	MS 0103821	6	M8-1.25 x 35MM S.H.C.S. (26ft-lb/36Nm)
7	MS 0104621	6	SHCS, M16x2.0x35MM (90ft-lb/122Nm)

V65 140D01950 Parts List

ITEM	PART NUMBER	QTY	DESCRIPTION
1	V65 6D00552	1	FLEXC 65 D COLLET SEAT
2	V65 6D00553	1	FLEXC 65 D CLAMP SLEEVE (NOT INCLUDED IN ASSEMBLY)
3	V65 01207	1	KEYSCREW
4	V65-01603	1	LOCATING STUD
5	V65 140DL02431	1	SPINDLE ADAPTER 140MM
6	MS 0103821	6	M8-1.25 x 35MM S.H.C.S. (26ft-lb/36Nm)
7	MS 0104019	6	SCREW SOC HD CAP M10 x 1.5 x 25MM (40ft-lb/54Nm)

Part No. BC -0009500-0154

Installation

The spindle adapter, clamping sleeve and collet seat are shipped assembled. The spindle adapter must be separated from the collet seat by removing the six mounting screws #6.

Clean, inspect and grease the machine spindle and the spindle adapter. Mount the spindle adapter to the machine spindle using the six fastening screws #7. For A2 style spindles, orient the spindle adapter with the drive button. Tighten the fastening screws according to the torque shown on the parts list. Flat back spindle adapters must be indicated before you torque the bolts to specification.

Check the concentricity and face runout of the spindle adapter before mounting the clamping sleeve and collet seat. Neither should exceed .0002" (5µm). If the indicator reading is more than .0002" (5µm), remove the spindle adapter and clean the surfaces again before remounting.

Reduce the clamping pressure of the machine to a minimum and extend the drawbar to the forward position. Carefully screw the clamping sleeve #2 onto the drawbar clockwise until it bottoms out. **DO NOT TIGHTEN**. Align the key in the collet seat with the keyway in the clamping sleeve to push the collet seat onto the spindle adapter. Rotate the body counterclockwise until the clearance holes in the body line up with the threaded holes on the spindle adapter. Carefully move the drawbar backwards and seat the collet seat into the spindle mount. Insert and tighten the six mounting screws #6 equally to the torque shown on the parts list.

Increase the clamping pressure to sufficient force for the job.

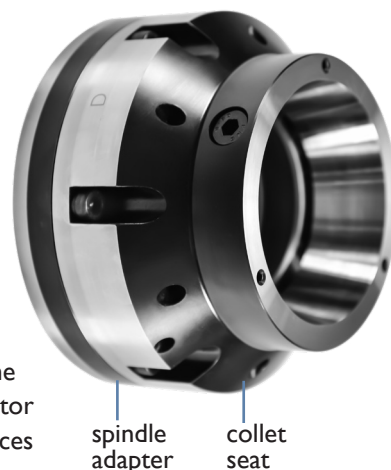

Checking the final Concentricity of the Collet Closing Taper

Locate the probe to touch the inside closing taper of the body to verify concentricity. This should not exceed .0002" (5µm). If the indicator reading is more than .0002" (5µm), remove the collet seat and clean the surfaces of the spindle adapter and the collet seat again before remounting. Check the concentricity again and repeat this step until the desired reading is met. Concentricity may be affected if using stock beyond the nominal gripping range.

Installing a Collet Head

Installing or changing of the collet head is possible only when the chuck is in the unclamped position. Prior to inserting the collet head you must clean the taper of the collet seat and the mating taper of the collet head.

Fully insert the pins of the manual wrench into the holes in the face of the collet head. Actuate or pull the lever to collapse the segments before inserting it into the body. Insert applying light pressure. Orient the keyway in the collet head with the key #3 in the collet seat. To release the collet head from the manual wrench you must press on the release button.

CAUTION: When actuating the manual wrench never reach inside the moving parts where there is risk of injury to your hand. Clean and lightly oil the collet head and the body before installing.



V65 6D00650 | 06/2022

Part No. BC -0009500-0154